

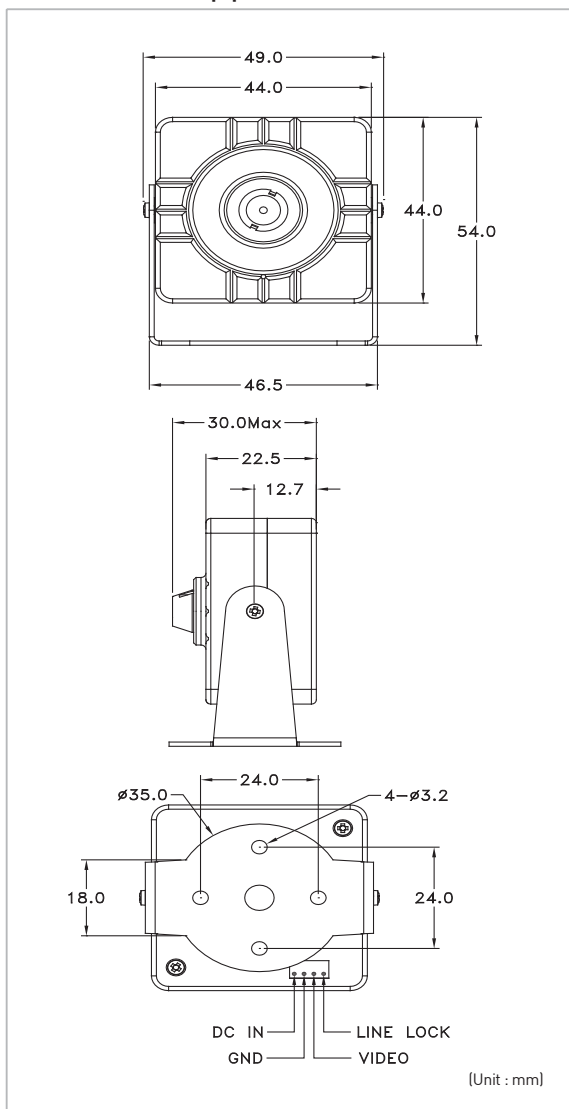

■ Outward Appearance



■ Features

- Wide dynamic range miniature camera
- High resolution picture quality through digital signal processor
- Wide voltage input operation
- Easy installation & operation

■ Lens Options

- FIXED BOARD LENS: 2.9MM, 3.6/3.7MM, 4.3MM, 6.0MM
- PHINHOLE LENS: 3.7MM, 4.3MM

■ Specifications

General Spec	KM-CB80	
	NTSC	PAL
Sensor	1/3" Interlaced color CCD (Double speed CCD)	
H,Resolution	480	
Scanning system	525 Lines interlaced	625 Lines interlaced
Video output	Composite (1.0Vp-p), 75Ω	
Synchronization	Internal / Line Lock	
Electronics iris	1/60 ~ 1/100,000	1/50 ~ 1/100,000
Light sensitivity	0.2Lux, With F1.2 30IRE	
Gamma	0.45	
S/N Ratio	46dB	
Input voltage	DC10~20V	
OSD Control	N/A	
Power consumption	MAX 3.0[W]	
Operating temperature	-10°C ~ +55°C	
Storage temperature	-20°C ~ +70°C	
Operating Humidity	90% RH (non-condensing)	
Connection	Video	BNC Cable
	Power	DC JACK
Dimension	48.5(W) X 54(H)	
Weight	127g (Without Lens)	
Certification	CE/FCC	